



VERSION CHARGEMENT PAR LE COUVERCLE

Ind	DATE		REDACTEUR	VERIFICATEUR	APPROBATEUR	OBSERVATIONS
0	07/06/99	Nom Visa	A.VILLENEUVE	D.BLIN	P.BERTET	Edition initiale
		Nom Visa				

TN 17 T SHUTTLE CASK FOR TRANSFERRING FUEL ASSEMBLIES AT TIHANGE, BELGIUM

I. Hunter (1), P. Samson (1), H. Libon (2), A. Villeneuve (1)

(1) Transnucléaire, 9-11 rue Christophe Colomb, 75008 Paris, France

(2) Transnubel, Gravenstraat 73, 2480 Dessel, Belgique

SUMMARY

This paper describes the TN 17 T shuttle cask and its operation at the Tihange spent fuel pool storage facilities in Belgium. The operational constraints and the diverse range of on-site facilities were evaluated by Transnucléaire and Transnubel to establish the cask options for both on-site and off-site transports. The selected cask concept is presented in outline terms and the main project stages are listed.

TIHANGE SITE

ELECTRABEL operates three different types of PWR reactors at Tihange:

Tihange 1	920 MWe (PWR 15x15 short)
Tihange 2	941 MWe (PWR 17x17 short)
Tihange 3	1054 MWe (PWR 17x17 long)

Additional storage facilities were constructed in 1997 in the form of a storage pool, the building is designated as "DE" and has been designed to accept fuel from each of the three units.

The concept of separate pool storage is in contrast to other systems in Belgium which, for the Doel power plant, utilise the TN 24 type dual purpose storage casks. Consequently, the on-site requirement is for a shuttle cask to feed the separate storage pool.

BASIC REQUIREMENTS FOR ON-SITE CASK MOVEMENTS

- The functional requirement is to transfer fuel from either Tihange 1, 2 or 3 to the DE facility. The primary objective is to transfer fuel into an interim storage facility. It is not specifically required to transfer fuel elements between units for further in core applications.
- The cask must interface smoothly with the existing cask operation system for each unit and the DE facility.

- The cask must conform to IAEA type B requirements with approval by the Belgian Competent Authority.
- Operational dose uptake to be minimised for both cask loading and unloading operations.

BASIC REQUIREMENT FOR OFF-SITE MOVEMENTS

- The cask must comply with the COGEMA acceptance criteria.
- The cask must confirm to IAEA type B requirements with approval by the Belgian and French competent authorities.
- Only fuel types Tihange 1 and Tihange 2 (short PWR fuel) are to be considered for off-site transports.

DESCRIPTION OF THE THIANGE SITE FACILITIES

Tihange 1 has a conventional cask loading pool and the facility is currently equipped to handle the Transnucléaire cask type TN 17/2. Consequently, any new cask must be designed within the following envelope conditions :

Maximum diameter: 2.0 m
 Maximum weight, loaded over pool: 80 tons

Tihange 2 and 3 are equipped with "under-pool" cask loading facilities which avoid submerging the cask in a fuel loading pool. The cask is placed on a special trolley and is connected to a sealing device. After removal of the pool plug, the fuel is transferred directly into the flask cavity. This system keeps the outside of the cask dry at all times and hence eliminates the need for external decontamination. Tihange 3 fuel is however 0.5 m longer than Tihange 2 fuel hence the two facilities differ in height. The cask interface equipment at Tihange 2 and 3 was developed to suit the TN 12/2, TN 13/2 cask types and no major changes are envisaged for the operation of the new cask.

Casks arrive horizontally before being lifted vertically into the preparation area. The cask handling crane does not cover the fuel storage facilities.

MAIN FUEL PARAMETERS FOR THE CASK(S)

Maximum average fuel burn-up for each cask loading:	50,000 MWd/tU
Maximum initial enrichment in U_{235} :	4.26 %
Minimum cooling time: Tihange 1 and 2 :	24 months
Tihange 3 :	60 months

PRELIMINARY DESIGN STUDIES

Transnucléaire and Transnubel undertook preliminary design studies during 1997. This study identified the following key parameters :

- Two types of cask would be required : a short version for Tihange 1 and 2 fuel assemblies and a longer version for Tihange 3 fuel assemblies.
- The short version must not exceed 80 t in the pool loading condition whereas the long version is limited to 120 tons.
- The Tihange 1 fuel parameters under dry internal cavity transport conditions provide envelope source terms for the cask shielding design.
- The cask external features such as trunnions and orifices must, as far as possible, be compatible with existing facilities.
- A closer study of operational aspects was required to determine the options for minimising operator dose uptake during cask loading and unloading.

Following a competitive tender, Transnucléaire and Transnubel were contracted by Synatom in 1997 to supply the TN 17 T shuttle cask. The detailed design and licensing application are programmed for 1998 and cask delivery is scheduled for 1999.

CASK DESIGN

Figure 1 shows the internal basket arrangement with 12 square lodgements for the fuel assemblies. The basket has been designed to facilitate heat transfer from the fuel to the cask inner wall for both dry and wet cavity conditions. In the case of a dry internal cavity, the predominant mode of heat transfer is radiation from the fuel to the basket and conduction within the basket structure to the cask inner wall. In the case of water filled cavity the conduction and convection within the water medium reduces the fuel cladding temperature but careful attention must be paid to internal pressures generated by radiolysis and the internal expansion of the water. Boronated aluminium profiles were selected for the basket structure, this concept having been well proven on other casks from the TN 24 family.

Figure 2 illustrates the two versions of the cask which share the same cask body and basket. Two separate cask bases are used to convert the cask from short to long versions.

A stainless steel, lead filled structure was chosen for the main part of the cask body because this provided maximum shielding efficiency within the weight and outer diameter limits. A layer of neutron shielding resin is encased by the outer steel shell and the external surface is finned to facilitate heat transfer. The cask upper part, lid and base are all stainless steel for easy decontamination.

There are 6 trunnions on each version for cask for handling and transport, the 4 upper trunnions being required for the cask lifting systems at Tihange.

In order to reduce the cycle time for cask loading, transfer and unloading in the DE facility, the cask cavity will be water filled during on-site transports. The complete cycle time expected to be less than 5 days giving an effective cask utilisation of several transfers per month.

The short version of the cask can also be used with a dry internal cavity for off-site transports to reprocessing facilities.

MAIN PARAMETERS OF THE TN 17 T CASK

		SHORT VERSION	LONG VERSION
CAPACITY	Tihange 1-2 fuel	10 or 12 fuel assemblies average burn-up 50,000 MWd/tU 24 months cooled	
	Tihange 3 fuel		12 fuel assemblies average burn-up 50,000 MWd/tU 5 years cooled
Length (mm)		< 5500	< 6200
Overall diameter (mm)		< 2000	< 2000
Weight (kg) - over pool - in transport condition		≤ 80 tons ≤ 92 tons	≤ 90 tons ≤ 105 tons
Maximum heat load (kW)		44	22

SAFETY ANALYSIS

Transnucléaire and Transnubel studied the cask safety for compliance with the relevant national and international regulations and the following codes have been used in assessing the cask performance:

Heat transfer ALGOR Super SAP Code distributed world-wide by ALGOR Inc., Pittsburgh, Pa USA. (thermal finite element code used for conduction and radiation thermal models)

FLUENT Code distributed in Europe by FLUENT France SA, Montigny le Bretonneux (thermal finite element code used for modelling natural and forced convection in fluids)

Source calculations ORIGEN 2 computer code, distributed by RSIC, Oak Ridge Term as Code Package CCC-371, January 1987 (determines the activity $[\gamma, \eta, \alpha, \beta]$ of fuel according to the burn-up history)

Radiation shielding	<p>SN1D Code User's manual - Report DMT 93/438 SERMA/LEPP/93/1532 from French CEA (G. Delonghe - L. Luneville), 30/09/1993 (calculates neutron dose rate and captured γ)</p> <p>MERCURE V Code" Report DMT 94/458 SERMA/LEPP/94/1670 from French CEA (C.Dupont), 02/09/1994 (primary γ dose rate predictions)</p>
Criticality	<p>APPOLO 2 Computer program: A.Hofmann and F.Jeanpierre; Multigroup Code for the resolution of the transport equation for fast and thermal neutron, note CEA N-1610 (from French CEA).</p> <p>MORET 4 Computer program: J.Moret-Bailly, G.Pouillot and J.R. Teillet; A Monte-Carlo program for rapid calculation of Effective Multiplication Coefficients of Fissile Mediums, Note CEA R-4752 (1976), (from French CEA).</p>
Structural	<p>LS-DYNA3D V.94, distributed by Dynalis France, rue La voisier, BP24, 91710 Vert Le Petit (dynamic impact analysis).</p> <p>ASME Boiler and Pressure Code (structural analysis)</p> <p>French CODAP (equivalent NFA norm used for pressure vessels)</p>
Radiolysis	<p>FACSIMILE V. 3.0, internal code of AEA Technology coded in FORTRAN 77. (predicts the generation rate of radiolytic hydrogen and oxygen gases)</p>

Conformity to the IAEA mechanical tests will be demonstrated by a programme of drop tests using fully representative one third scale models equipped with a basket and simulated fuel assemblies in both the wet and dry cavity configurations.

CONCLUSIONS

The TN 17 T cask provides a safe and efficient means of transferring fuel assemblies between the different installations at Tihange. The same cask can also be used for off site transports to another power plant, to a different interim storage facility, or to reprocessing plants.

The design concept has been optimised to minimise dose uptake to cask operators.

By selecting a design with a removeable base, the cask can be readily converted to accommodate the different fuel assembly types to be transported at the Tihange site.

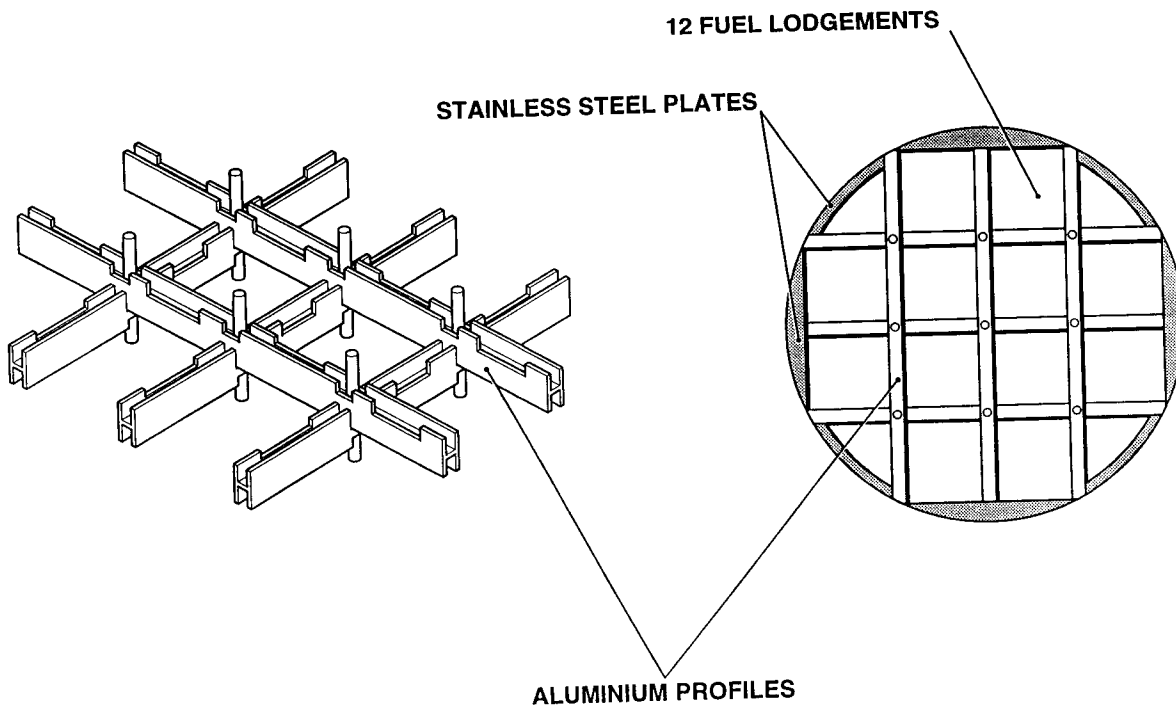

Figure 1: TN 17 T Cask internal arrangement

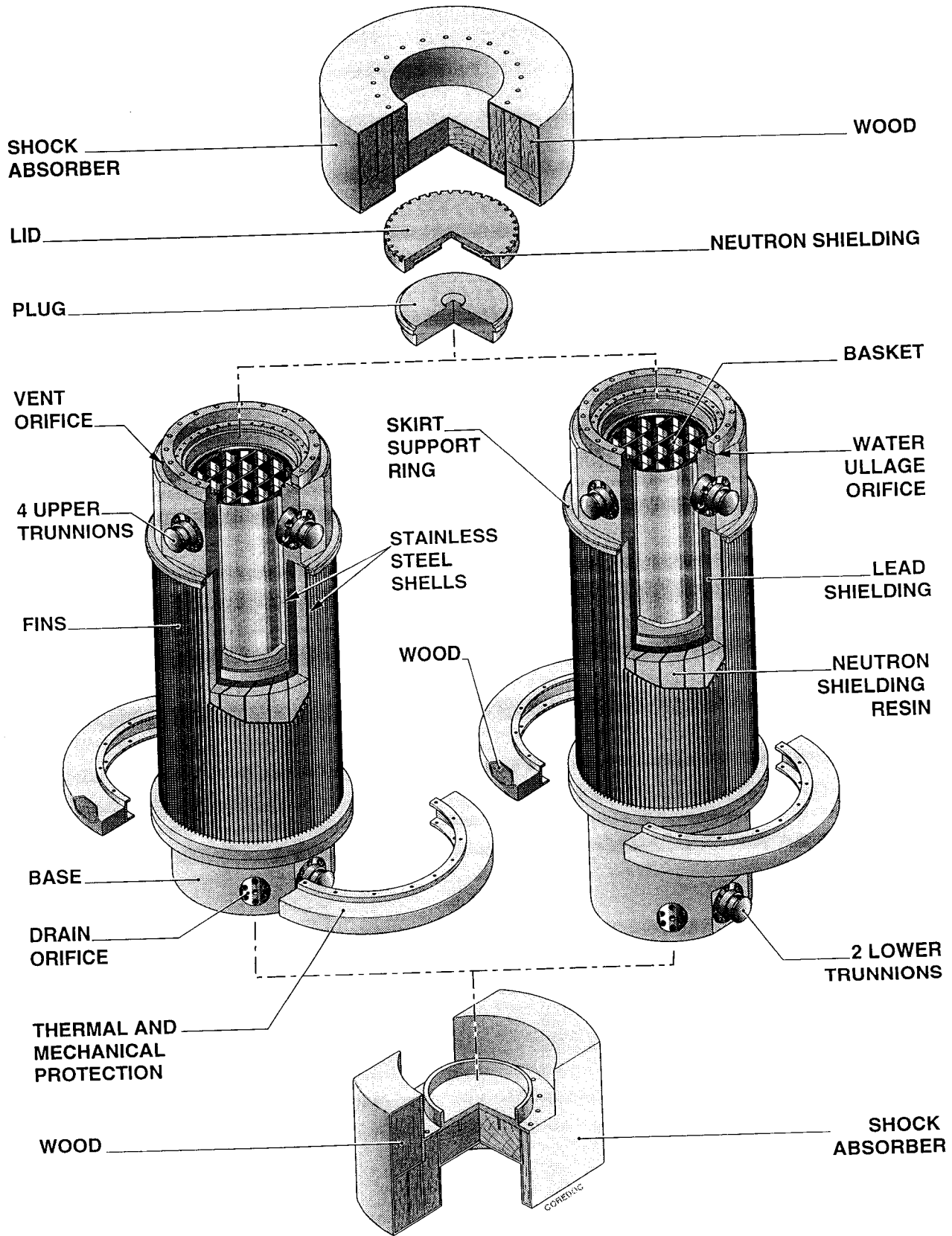

Figure 2: TN 17 T Cask (short and long versions)