

IP Strategies

Trends in Patent, Copyright, Trademark and Technology Development and Protection

DESIGN PATENTS PROVIDE AN INEXPENSIVE AND EFFECTIVE MEANS OF INTELLECTUAL PROPERTY PROTECTION AND SHOULD BE CONSIDERED FOR BUILDING AN INTELLECTUAL PROPERTY PORTFOLIO

Although product creators and manufacturers may initially consider the popular utility patent as a way to protect their products, design patents may also provide a strategic avenue for obtaining intellectual property protection and should not be overlooked when formulating an intellectual property portfolio strategy.

The more popular utility patent provides a protection mechanism for the *utilitarian* features of an invention, that is, the useful features or how an article is used and works. To obtain a utility patent for an invention, the patent applicant must meet the tests of novelty and non-obviousness, show that the claimed subject matter falls within a patentable category, and provide a sufficient specification such that *one of ordinary skill in the art* will be able to make and use the invention described.

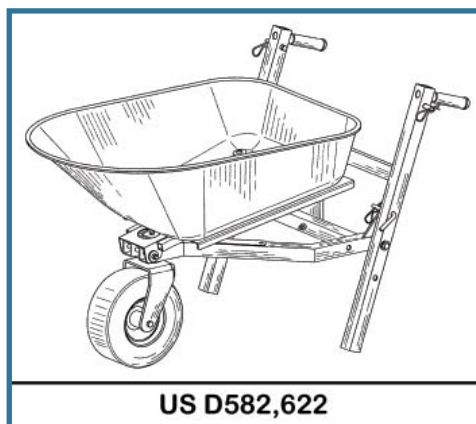

US D582,622

Unlike a utility patent, a design patent protects only the visual or *ornamental* characteristics of a product, in other words, how the product looks. In fact, a design patent can contain

only a single claim worded such as, “*The ornamental design of an [article] as shown and described.*”

Unlike a claim in a utility patent, which is defined by the *words* of the claim, the claim in a design patent is the *drawing* or drawings. While the “article” must be named in the claim, such as a “lamp shade” or “shower caddy,” the most critical segment of a design patent is the drawings portion which must provide a sufficient number of views to disclose the complete appearance of the claimed design.

It is therefore important to file a design patent application only *after* a design has been finalized and is ready for release, such as presentation at a trade show or for production. If a design patent application is filed

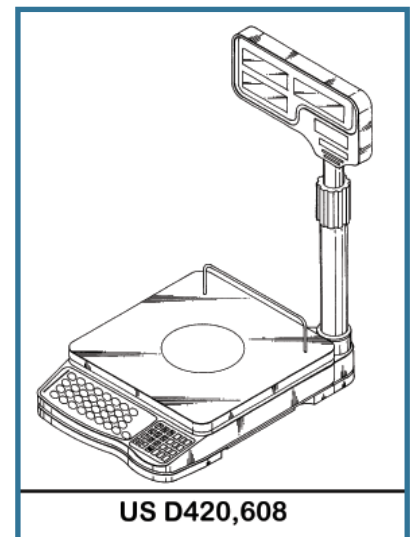

US D420,608

in this issue...

Design Patents Provide Inexpensive and Effective Protection.....	1
Patentees May Have Duty to Disclose Standard Related Patents to Standards Setting Organization.....	5
Elements in Single Prior Art Reference Can Be Combined to Make Claims Invention Obvious	8
Expert Witness Must Qualify in Pertinent Art.....	9
Courts Have Broad Discretion to Grant or Deny Injunctions in Patent Cases.....	10

prior to the final product design version, any changes made to the actual product design would not be covered by the design patent. The design intended to be covered must be the design shown in the drawings of the design patent application.

The statutory language that provides the basis for design patent protection is 35 U.S.C. § 171, which states that an applicant may obtain a design patent for “any new, original, and ornamental design for an article of manufacture” provided that the legal requirements are met. The Manual of Patent Examining Procedure (MPEP) asserts that the case law has interpreted the language “new, original and ornamental design for an article of manufacture” to include at least three types of designs including:

A) “an ornament, impression, print, or picture applied to or embodied in an article of manufacture (surface indicia);”

B) “the shape of configuration of an article of manufacture;” and

C) combinations of A and B.

It is important to note that while a design patent claims the look of a product, this does not preclude the product from having a utilitarian purpose. The necessary consideration for design patentability is that the appearance must not be dictated by the product’s use, but rather must be for esthetic purposes. However, as stated in the MPEP “[t]he design for an article *cannot be assumed* to lack ornamentality merely because the article of manufacture would seem to be

primarily functional.”

An understanding of the wide scope and variety of “articles of manufacture,” or products, that may be covered by a design patent may be obtained by a review of the USPTO’s Design Patent Classes. As set forth in the table on page 3, the USPTO currently lists 33 Design Patent Classes and a catch-all

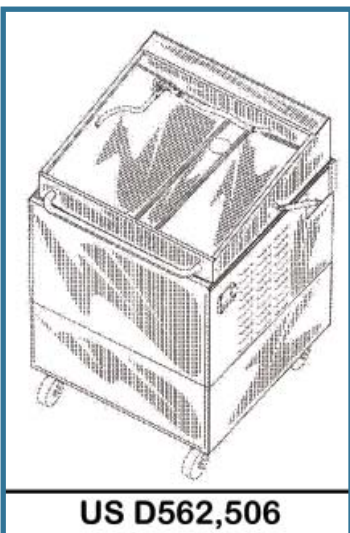

category, “Miscellaneous.” Virtually any type of product will fit into one or more of the Design Patent Classes.

Design patents have been obtained for everything from “Aqueous Parts Cleaners” to “Wireless Transceivers,” and examples of both of these are shown below as reproduced from actual design patents.

These examples illustrate that a utilitarian apparatus may be subject matter for a design patent if the apparatus embodies an ornamental design.

Examples of design patents are numerous and are illustrative of the wide scope of articles that fall within the purview of design patent protection. Another example is a “Shrimp Cocktail Serving Container” claimed in U.S. Design Patent D547,128 (issued Jul. 24, 1997). Figure 1 of the design patent is reproduced below.

A design patent has a term of 14 years from its date of issue, in contrast to a utility patent, which has a term of 20 years from its date of filing. Per the most recent USPTO fee schedule, the filing fees for a design patent application (filing, search and examination fee) are only \$460.00 versus \$1,090.00 for a utility patent application. For a small entity, the fee is reduced by half.

A design patent portfolio can therefore be of critical value to any inventor or business, including a small business or startup, that has a unique product

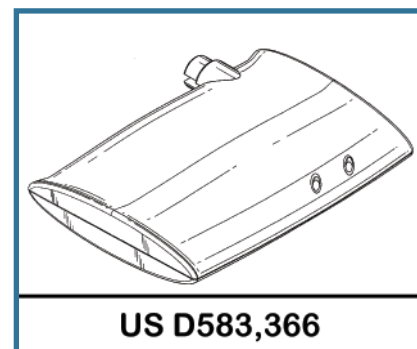

USPTO Design Patent Classes	
Class	Description
D01	Edible products
D02	Apparel and haberdashery
D03	Travel goods and personal belongings
D04	Brushware
D05	Textile or paper yard goods; sheet material
D06	Furnishings
D07	Equipment for preparing or serving food or drink not elsewhere specified
D08	Tools and hardware
D09	Packages and containers for goods
D10	Measuring, testing, or signaling instruments
D11	Jewelry, symbolic insignia, and ornaments
D12	Transportation
D13	Equipment for production, distribution, or transformation of energy
D14	Recording, communication, or information retrieval equipment
D15	Machines not elsewhere specified
D16	Photography and optical equipment
D17	Musical instruments
D18	Printing and office machinery
D19	Office supplies; artists' and teachers' materials
D20	Sales and advertising equipment
D21	Games, toys, and sports goods
D22	Arms, pyrotechnics, hunting and fishing equipment
D23	Environmental heating and cooling; fluid handling and sanitary equipment
D24	Medical and laboratory equipment
D25	Building units and construction elements
D26	Lighting
D27	Tobacco and smokers' supplies
D28	Cosmetic products and toilet articles
D29	Equipment for safety, protection and rescue
D30	Animal husbandry
D32	Washing, cleaning or drying machine
D34	Material or article handling equipment
D99	Miscellaneous

appearance and needs to be protected from copying by others. A design patent provides this necessary protection against copying and can be a determining factor in the types of obtainable damages.

One example of a successful design patent court action, filed in the U.S. District Court for the Northern District of Illinois, involved a defendant who was copying and importing a patented stackable shelf and shower caddy. The patents involved were U.S. Design Patents D485,092 (issued Jan. 13, 2004) for the "Stackable Shelf" and D489,207 (issued May 4, 2004) for the "Shower Caddy."

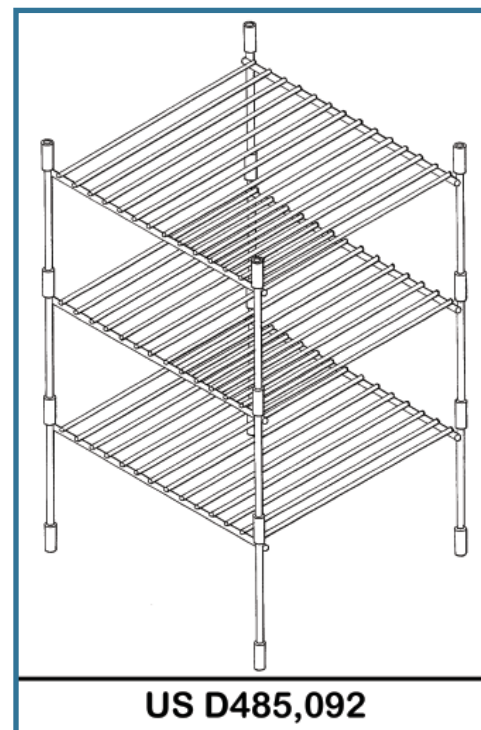

The defendant engaged an overseas manufacturer in China to produce copies of the patented designs for sale in the U.S. The patent owner successfully obtained a very favorable settlement based on the sales, against both the defendant and the manufacturer in China. Although the court action involved trade dress and copyright claims as well as patent infringement, the infringement claim presented liability for willful infringement and attorney fees, which would not have been possible under the trade dress or copyright claims alone.

Recent Federal Circuit case law has also proved favorable to design patent holders in terms of the law of infringement determination.

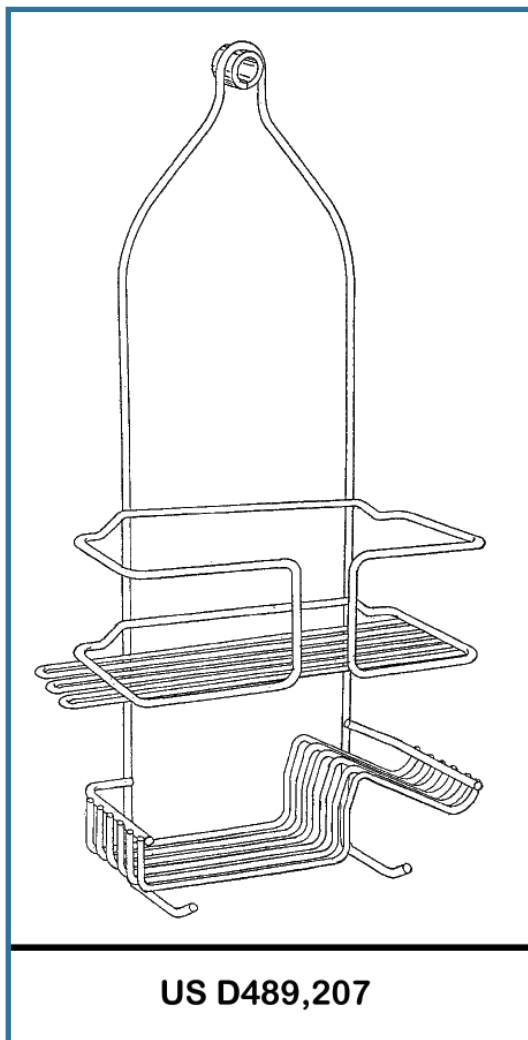

In *Egyptian Goddess, Inc. v. Swisa, Inc.* (Fed. Cir. 2008), the Federal Circuit held that the test for infringement is the “ordinary observer” test and that the “point of novelty” test should no longer be used in the analysis of a claim of design patent infringement. Under the point of novelty test, courts held that to prove infringement of a design patent, a plaintiff needed to show that, in addition to an accused device being “substantially similar” to the claimed design, the accused device contained “substantially the same points of novelty that distinguished the patented design from the prior art.” The Federal Circuit in *Egyptian*

Goddess held that the point of novelty test should no longer be used and stated that the sole test for determining infringement of a design patent is whether “the accused article embodies the patented design or any colorable imitation thereof.” The “ordinary observer” test was originally set forth by the Supreme Court in *Gorham Co. v. White*, 81 U.S. 511 (1871), which involved a design patent for tablespoon and fork handles.

An accused design will still be viewed in the context of the prior art, however, especially if the prior art area is crowded. The question under the standard is whether an ordinary observer, familiar with the prior art designs, would be deceived into believing the accused product to be the same as the patented product.

One can see that the infringement standard articulated by the Federal Circuit affords a design patent holder a measure of protection from willful copiers who seek to produce knock-off versions of the patented product. Further, all the remedies available to a utility patent holder are likewise applicable to a design patent holder, that is, injunction and damages, including damages for willful infringement. Importation into the U.S. may also be blocked using a design patent.

USPTO statistics show that the number of design patent grants, from patents originating in the U.S., has risen from 7554 in 2005 to 13,494 in 2007, a 78% increase. However, foreign originating U.S. design patent grants have risen from 5397 in 2005 to 10,569 in 2007, a 95% increase over the same period. The key players in 2007 were Japan with 2417 grants, Taiwan with 1355, South Korea with 957 and Germany with 810. China with 462 grants in 2007 had a 183% increase over its 2005 design patent grants and has been steadily increasing its share of design patents since 1999.

In spite of these increases, the overall number of design patents granted per year is still small compared to the number of utility patent grants, which numbered over 200,000 for 2007. This may be an indication that the power of design patents may not be fully appreciated by current U.S. businesses.

Therefore, design patents should be considered as a part of an initial or overall intellectual property portfolio and may provide a cost-effective means of product

protection for individual inventors or business entities of any size.

**PATENTEES MAY HAVE A DUTY TO
DISCLOSE STANDARD RELATED PATENTS
TO STANDARDS SETTING ORGANIZATION**

Qualcomm Inc. v. Broadcom Corp.
(Fed. Cir. 2008)

For patents relating to a standardized technology, participation in a standards organization's development efforts in any capacity may impose a duty upon the patentee to disclose its standards related patents to the standards setting organization ("SSO").

While *Qualcomm Inc. v. Broadcom Corp.* is a case concerning inequitable conduct on the part of *Qualcomm* with respect to its duty to disclose known intellectual property rights, the case is informative for all who participate in SSOs and develop patents related to developing standards.

For *Qualcomm's* case on appeal, the Federal Circuit reviewed the questions of (1) the existence of a disclosure duty to an SSO; (2) the scope of the SSO disclosure duty; (3) whether such a duty was breached; and (4) whether the District Court had equitable authority to impose a patent unenforceability remedy in the case. A brief synopsis of the Federal Circuit's analysis and discussion of the District Court's holdings serves as a tutorial of the issues involved for an SSO participant who is also a patentee.

**Even if an IPR written policy
has no explicit requirements for
disclosure, a duty may still be
found by a court based on the
understanding of the participants**

Most SSOs impose requirements on their participants to disclose, and possibly give up, intellectual property rights (IPR) related to standards developed by the SSO. This is because, in many instances, SSOs expect the public to utilize and promulgate technology related to the standard and

therefore expect the public to have access without limitations and cost due to the IPR of others. Toward this purpose, most SSOs have a written IPR policy that sets forth the expectations for disclosure of IPR by its participants.

The rub for SSO participants is that a reading and interpretation of an SSO's written IPR policy is not sufficient in itself to determine whether a participant has a duty of disclosure. Although a court will look to whether a written IPR policy imposes any disclosure obligations on participants, it will also look at how the other participants understood the policy and whether the policy was viewed by other participants as imposing an obligation.

Even if an IPR written policy has no explicit requirements for disclosure, a duty may still be found by a court based on the understanding of the participants. For example, in *Qualcomm*, the Federal Circuit discussed its previous holdings in *Rambus Inc. v. Infineon Technologies AG*, 318 F.3d 1096 (Fed. Cir. 2003). In *Rambus*, the Federal Circuit reviewed an SSO written IPR policy and found no express duty imposed on members of the SSO. However, because the SSO members treated the language of the policy as imposing a disclosure duty, the court likewise treated the language as imposing a disclosure duty.

This is akin to stating that the "majority rules" with respect to perceiving the existence of an IPR disclosure duty, even if the IPR policy is silent as to a duty or is otherwise ambiguous. The "treatment" of an IPR policy's language as imposing a duty based on SSO participant behavior may create a disturbing legal reality for participants who believed they were in compliance with an SSO IPR policy based on their reading and interpretation of the written policy's language. If such a disclosure duty is neglected, an implied waiver of patent rights may occur.

The Federal Circuit, in analyzing the *Qualcomm* case on appeal, repeated the wording of the District Court and stated that, "a duty to speak can arise from a group relationship in which the working policy of disclosure of related intellectual property rights ('IPR') is treated by the group as a whole as imposing an obligation to disclose information in order to support and advance the purposes of the group."

Qualcomm's problems began when they filed suit against Broadcom for infringement of two patents that Qualcomm argued were necessary for any product implementing the H.264/MPEG-4 AVC (Advanced Video Coding) video compression standard. The *Qualcomm* case went to the jury and a verdict of non-infringement was returned for both of Qualcomm's patents. However the jury also returned a unanimous advisory verdict and found by clear and convincing evidence that one of the two patents was unenforceable due to inequitable conduct, and that both patents were unenforceable due to waiver.

In *Qualcomm Inc. v. Broadcom Corp.*, Qualcomm appealed the decision of the U.S. District Court for the Southern District of California, holding that, due to Qualcomm's breach of duty to the SSO and inequitable conduct during the trial of withholding evidence that Qualcomm was a participant in the relevant SSO, the two Qualcomm patents that were *related to* the resultant standard, were unenforceable against the world. The Federal Circuit vacated the patent unenforceability ruling with respect to its breadth, limiting unenforceability only to H.264-compliant

the Federal Circuit concluded
that the District Court "may in
appropriate circumstances order
patents unenforceable as a result
of silence in the face of an SSO
disclosure duty"

products. However, even this narrower ruling likely defeated the intended purpose of obtaining the H.264 related patents and also destroyed the two patents' value.

The value of a patented technology that is *required* in order to implement a standard is readily apparent. Infringement of such a patent can be determined merely by the fact that an accused product *complies with the standard*. Compliance therefore automatically equals infringement. Such patents are sometimes referred to as *essential* to the standard, or *necessary* for the standard in the District Court's language.

Waiver was raised by Broadcom as an affirmative defense to the allegation of patent infringement. The waiver theory was that, since Qualcomm had a duty to disclose its IPR during the development of the standard, and breached its duty by remaining silent, it waived its right to later assert the non-disclosed patents against those complying with the standard. Qualcomm argued that once the non-infringement determination was reached, the court lacked legal basis to further consider waiver and apply it in a judgment of patent unenforceability. However, the Federal Circuit concluded that the District Court "may in appropriate circumstances order patents unenforceable as a result of silence in the face of an SSO disclosure duty, as long as the scope of the district court's unenforceability remedy is properly limited in relation to the underlying breach."

Qualcomm was an active dues paying member, and participant in the relevant SSO. However, they argued during trial that they did not participate in the SSO during development of the H.264 standard. E-mails were later produced that showed that Qualcomm did in fact participate in the SSO and attempted to conceal evidence of participation during the trial.

Regarding the written IPR policy, and the question of existence of a duty of disclosure, the policy was somewhat different from the policy discussed in *Rambus* in that there was no duty to disclose patents unless a member submitted a technical proposal. The written IPR policy also stated that, "members/experts are encouraged to disclose as soon as possible IPR information (of their own or anyone else's) associated with any standardization proposal (of their own or anyone else's)." This information was to be provided "on a best effort basis." The District Court also concluded that the SSO members treated the IPR policy "as imposing a duty of disclosure on participants apart from the submission of technical proposals."

Qualcomm argued it had no duty since it did not submit any technical proposals and that the written policy only "encouraged" disclosure. However, the Federal Circuit disagreed and held that the "best efforts" requirement required disclosure even apart from submission of technical proposals. The Federal Circuit also found a duty imposed by language in a

broader IPR policy that covered various subsections of an overall SSO.

The question remained as to which patents needed to be disclosed in order to satisfy the disclosure duty. The District Court articulated the “reasonably might be necessary” standard, which the Federal Circuit elaborated upon stating that, “the disclosure duty operates when a reasonable competitor would not expect to practice the standard without a license under the undisclosed claims.” Although the Court stated that “[t]his formulation does not require that the patents ultimately must “actually be necessary” [as argued by Qualcomm] to practice the H.264 standard,” it is difficult to decipher how a competitor would not

SSO participants need to be aware of the understandings and consensus of the participant group with respect to treatment of IPR

expect to practice the standard without licensing the not “actually necessary” patent claims. In other words, one would think that, if the competitor expected that a license would be needed in order to practice the standard, then the patent claims must have been “actually necessary.”

In contrast to this thinking, the Court’s approach here seems to indicate that, during the development of a standard, it is not yet certain whether any specific patent will “actually be necessary.” However, one may be able to discern that a patent “reasonably might be necessary” based on knowledge of the direction the standard is taking based on participation.

Qualcomm’s argument was that the Court in *Rambus* stated that “it must be reasonably clear at the time that the patent or application would actually be necessary to practice the standard.” Thus, Qualcomm argued that “the court really meant that the patent or application must “*actually* be necessary” to practice the standard.” The Federal Circuit disagreed, as discussed above.

Qualcomm’s actions according to the evidence showed that the disclosure duty was breached, and the Federal Circuit affirmed the District Court’s decision with respect to its equitable authority to impose the unenforceability remedy upon the two asserted patents.

In summary, SSO participants need to be aware of the understandings and consensus of the participant group with respect to treatment of IPR. Any written IPR policies are relevant to the extent that such policies expressly provide disclosure duties and obligations. But the determinative factor as to whether a duty exists, and the scope of the duty, lies with the participant group consensus. Participants may also expect to disclose IPR consistently over time, as their various segments of IPR “reasonably might be necessary” to implement the standard as the standard content changes during the development cycle.

Practice Tip:

A reading of the written language of an SSO IPR policy alone is not sufficient for determining a participant’s duty of disclosure with respect to the SSO.

Case Law Review

ELEMENTS IN A SINGLE PRIOR ART REFERENCE COMBINED TO OBTAIN PATENT

Boston Scientific v. Cordis

(Fed. Cir. 2009)

Elements disclosed in different embodiments of a single prior art reference can be combined to find claims obvious, according to the Federal Circuit.

In 2003, Boston Scientific sued Cordis for infringing U.S. Patent 6,120,536 (the '536 patent), which relates to a drug-eluting expandable stent with a coating that has a non-thrombogenic surface. The stent has a metal core surrounded by a drugged layer that is surrounded by the non-thrombogenic layer. At trial, the jury found that the asserted claims were infringed and would not have been obvious based on, among other references, U.S. Patent 5,545,208 (the '208 patent) and U.S. Patent 5,512,055 (the '055 patent). The District Court upheld the jury's findings and denied Cordis's motion for judgment as a matter of law.

With regard to the finding of non-obviousness, the district court reasoned that the '055 patent, which discloses esophageal stents, does not suggest the use of metal in a stent, and that there was no evidence of motivation to combine the '055 patent with other references. In addition, the District Court reasoned that the '208 patent does not teach a metallic stent having a two-layer coating, and the failure of the assignee of the '208 patent to create the claimed stent after more than a decade of work evidenced a lack of motivation to combine the features of its various prior art stents with each other.

On appeal, Cordis argued that the District Court erred in denying Cordis's motion for JMOL of invalidity of the '536 patent on the ground of obviousness. According to Cordis, the '208 patent alone rendered the asserted claims obvious. The '208 patent discloses two embodiments in Figures 3B and 4. Figure 3B discloses a polymer stent made of a drug-eluting polymer with a barrier topcoat. The stent and the topcoat are referred to in the patent as separate

"layers." Figure 4 discloses a metallic stent with a drug-eluting polymer coating. The drug-eluting polymer coating in Figure 4 is referred to with the same numeral as the drug-eluting polymer stent of Figure 3B.

Applying *KSR Int'l v. Teleflex*, the Federal Circuit found that it would have been obvious to combine the embodiment in Figure 3B with the embodiment in Figure 4 to arrive at a metal stent with two coating layers. The Federal Circuit stated that combining the two elements disclosed adjacent to each other in a prior art patent does not require a leap of inventiveness. Accordingly, the Federal Circuit reasoned that 35 U.S.C. § 103 bars patentability because the combination of the two embodiments was simply a predictable variation. The Federal Circuit stated that the weak secondary considerations of non-obviousness do not overcome the strong prima facie showing that the '208 patent renders the asserted claims obvious.

Practice Tip:

When evaluating patentability of an invention, it may be beneficial to pay close attention to the elements of various embodiments disclosed in a prior art reference that can be combined to render a predictable variation.

**AN EXPERT WITNESS TESTIFYING ON
INFRINGEMENT AND INVALIDITY MUST QUALIFY
AS AN EXPERT IN THE PERTINENT ART**

Sundance, Inc. v. DeMonte Fabricating, Ltd.
(Fed. Cir. 2009)

A witness is not qualified to testify as an expert on the issues of infringement and validity unless that witness is qualified as an expert in the pertinent art, according to the Federal Circuit.

Sundance sued DeMonte for infringing U.S. Patent 5,026,109 (the '109 patent), which is directed to retractable segmented covering systems for “almost any structure or container,” such as truck trailers, swimming pools, porches, and patios. A jury concluded

the Federal Circuit that held it was an abuse of discretion to permit a witness to testify as an expert on the issues of infringement and validity unless that witness is qualified in the pertinent art

that the asserted claim was infringed but invalid for obviousness under 35 U.S.C. § 103. Following the jury verdict, Sundance moved for judgment as a matter of law that the '109 patent was not invalid. The district court granted Sundance's motion and denied DeMonte's motion asking for reconsideration in light of *KSR Int'l v. Teleflex*.

At trial, DeMonte presented two prior art references to the jury as a basis for obviousness. DeMonte's patent law expert opined that one of ordinary skill in the art would be motivated to combine the two prior art references resulting in the asserted claim. The jury determined that the asserted claim of the '109 patent was obvious in view of the two prior art references.

The Federal Circuit held that the district court abused its discretion by letting the patent law expert testify as an expert witness on the issues of infringement and validity. Despite the absence of any

suggestion of relevant technical expertise, the patent law expert offered testimony on several issues that are exclusively determined from the perspective of ordinary skill in the art. The Federal Circuit stated that the patent law expert had no experience whatsoever in the field of tarps or covers and that his experience with engines is not sufficiently related. Therefore, according to the Federal Circuit, the patent law expert is not qualified as an expert by knowledge, skill, experience, training, or education in the pertinent art and could not assist the jury to understand the evidence or to determine a fact in issue. The Federal Circuit stated that admitting testimony from such an expert, with no skill in the pertinent art, serves only to cause mischief and confuse the jury. Accordingly, the Federal Circuit held that it was an abuse of discretion to permit a witness to testify as an expert on the issues of infringement and validity unless that witness is qualified in the pertinent art.

However, the Federal Circuit stated that the expert testimony was not required because there were no underlying factual issues in dispute as to obviousness. According to the Federal Circuit, the technology is simple and does not require expert testimony in order to find the asserted claim obvious. As such, the Federal Circuit held that the asserted claim was obvious regardless of the admissibility of the patent law expert's testimony.

Practice Tip:

When obtaining an expert witness to testify as on the issues of infringement and validity make sure that the witness is qualified as an expert in the pertinent art.

**POST-EBAY COURTS HAVE BROAD DISCRETION
TO GRANT PERMANENT INJUNCTIVE RELIEF**

Acumed LLC v. Stryker Corp.

(Fed. Cir. 2009)

A court applying the four-factor test set forth in *Ebay v. MercExchange* has broad discretion to grant a permanent injunction so long as it does not commit legal error nor make any clearly erroneous factual findings, according to the Federal Circuit.

Acumed sued Stryker for infringing U.S. Patent 5,472,444, which is directed to a proximal nail, a type of orthopedic nail used for the treatment of fractures of the humerus, or upper arm, bone. A jury found that Stryker had willfully infringed certain claims of the patent and awarded damages based on lost profits and a reasonable royalty. The District Court granted Acumed's motion for permanent injunction, applying the general rule in patent cases that an injunction will issue, once infringement and validity have been adjudged, unless there are some exceptional circumstances that justify denying injunctive relief.

While Stryker's appeal to the Federal Circuit was pending, the U.S. Supreme Court decided *Ebay v. MercExchange*, which held that the traditional four-factor test for permanent injunctions must be faithfully applied in patent cases as in other types of cases. The Federal Circuit subsequently affirmed the District's Court of willful infringement, but vacated the permanent injunction (which had been stayed) and remanded the case to the District Court for reconsideration in light of *Ebay v. MercExchange*. The District Court applied the four-factor test and granted the permanent injunction. The Federal Circuit reviewed the District Court's decision to grant a permanent injunction for abuse of discretion.

***Irreparable Harm and
Lack of Adequate Remedy at Law***

The Federal Circuit considered the first two factors, irreparable harm and lack of adequate remedy at law, together. Stryker argued that the District Court erred in giving weight to Acumed's previous decisions to license the patent to two other competitors. According to

Stryker, Acumed's past willingness to grant licenses demonstrates that money damages in the form of a reasonable royalty are an adequate remedy. Acumed rebutted, stating that the amount of weight given to a patentee's prior willingness to grant licenses is solely within the discretion of the court.

In holding that the District Court did not abuse its discretion, the Federal Circuit stated that the essential attribute of a patent grant is that it provides a right to exclude competitors from infringing the patent. In view of that right, stated the Federal Circuit, infringement may cause a patentee irreparable harm not remediable by a reasonable royalty. The fact that a patentee has previously chosen to license the patent may indicate that a reasonable royalty does compensate for an infringement, but that is just one factor to consider, according to the Federal Circuit. The Federal Circuit stated that a plaintiff's past willingness to license its patent is not sufficient per se to establish lack of irreparable harm if a new infringer were licensee. Accordingly, the Federal Circuit concluded that the District Court did not abuse its discretion in finding that Acumed suffered irreparable harm from Stryker's infringement with no adequate remedy at law.

Balance of Hardships

Stryker argued that the District Court abused its discretion because Stryker customers and patients (with fractured upper arm bones) would endure hardships under the injunction. In finding that the District Court did not abuse its discretion, the Federal Circuit stated that the balance considered is only between a plaintiff and a defendant, and thus the effect on customers and patients alleged by Stryker was irrelevant under this prong of the injunction test. Accordingly, the Federal Circuit concluded that the District Court did not abuse its discretion in determining that the balance of hardships tips in favor of Acumed.

Public Interest

Stryker argued that the District Court abused its discretion in essentially placing the burden on Stryker, rather than Acumed, with regard to the public interest factor because Acumed's product is of a lower quality

and is not as safe Stryker's product. The Federal Circuit stated that the District Court did not abuse its discretion in concluding that there was not sufficient evidence of a public health issue with Acumed's product. The Federal Circuit also stated that the District Court did not shift the burden to Stryker; rather, the District Court merely found that Acumed had made a *prima facie* showing that its product works. The Federal Circuit concluded that given the District Court's review of the evidence presented, the Court was within its discretion to conclude that the public interest was not disserved by an injunction.

Holding

After review of the four-factor test set forth in *Ebay v. MercExchange*, the Federal Circuit concluded that the District Court did not abuse its discretion because it performed the required analysis, and in doing so, committed no legal error and made no clearly erroneous factual findings.

Comment:

This case illustrates the broad scope of discretion granted to district courts in granting permanent injunctions.

VEDDERPRICE®

222 NORTH LASALLE STREET
CHICAGO, ILLINOIS 60601
312-609-7500 FAX: 312-609-5005

1633 BROADWAY, 47th FLOOR
NEW YORK, NEW YORK 10019
212-407-7700 FAX: 212-407-7799

875 15th STREET NW, SUITE 725
WASHINGTON, D.C. 20005
202-312-3320 FAX: 202-312-3322

Technology and Intellectual Property Group

Vedder Price P.C. offers its clients the benefits of a full-service patent, trademark and copyright law practice that is active in both domestic and foreign markets. Vedder Price's practice is directed not only at obtaining protection of intellectual property rights for its clients, but also at successfully enforcing such rights and defending its clients in the courts and before federal agencies, such as the Patent and Trademark Office and the International Trade Commission, when necessary. We also have been principal counsel for both vendors and users of information technology products and services.

IP STRATEGIES is a periodic publication of Vedder Price P.C. and should not be construed as legal advice or legal opinion on any specific facts or circumstances. The contents are intended for general informational purposes only, and you are urged to consult your lawyer concerning your specific situation and any legal questions you may have. For purposes of the New York State Bar Rules, this newsletter may be considered ATTORNEY ADVERTISING. Prior results do not guarantee a similar outcome.

We welcome your suggestions for future articles. Please call Angelo J. Bufalino, the Intellectual Property and Technology Practice Chair, at 312-609-7850 with suggested topics, as well as other suggestions or comments concerning materials in this newsletter.

IP Strategies**Editor-in-Chief**

Angelo J. Bufalino 312-609-7850

Executive Editor

Robert S. Beiser 312-609-7848

Contributing Authors

Joseph T. Cygan..... 312-609-7945

Jimmie K. Tolliver 312-609-7788

© 2009 Vedder Price P.C. Reproduction of this newsletter is permitted only with credit to Vedder Price P.C. For additional copies or an electronic copy of this newsletter, please contact us at info@vedderprice.com.

About Vedder Price

Vedder Price is a national business-oriented law firm with 250 attorneys in Chicago, New York and Washington, D.C.

Principal Members of the Intellectual Property Group

Angelo J. Bufalino, *Practice Group Leader*

Robert S. Beiser

Joseph T. Cygan

Mark A. Dalla Valle

Jeffrey C. Davis

W. Dennis Drehkoff

James. T. FitzGibbon

John J. Gresens

Christopher P. Moreno

Christopher J. Reckamp

Robert S. Rigg

Jimmie K. Tolliver

Michael J. Turgeon

Alain Villeneuve

William J. Voller III

Richard A. Zachar

